

GSM and GPS Vehicle Tracking Alarm System

User Manual



Please read it carefully before operation and installation

Content

1. Product Introduction
 - 1.1. Basic Components
 - 1.2. Buttons of the Remote Control
 - 1.3. Model and Apply
 - 1.4. Technical Specification
2. Original Settings
 - 2.1. Insert a SIM Card
 - 2.2. Set and Modify the Password
 - 2.3. Alarm Phone Number
 - 2.4. Set Emergency Help Number
 - 2.5. Delete an Alarm Telephone Number
 - 2.6. Password
 - 2.7. Telephone Operation
3. Functions and Operation
 - 3.1. Sound and Light Alarm
 - 3.2. Mute Alarm
 - 3.3. Armed Reminder (optional)
 - 3.4. Trigger Alarm (optional)
 - 3.5. Third Alarm Phone Number (optional)
 - 3.6. Alarm Report
 - 3.7 Alarm priority
 - 3.8. Reminding to Set the Phone Number Beforehand
 - 3.9. Safety Reminding (optional)
 - 3.10. Dialer/Remote Control Learning Code
 - 3.11. Reporting Incoming Telephone Number
 - 3.12. Hacker Memory
 - 3.13. Disarming and Auto Rearming
 - 3.14. Emergency Help Alarm
 - 3.15. Remote Trunk Release
 - 3.16. Help
 - 3.17. Arming Reminder (optional)
 - 3.18. Closing Door Reminder
 - 3.19. Automatic Central Lock System
 - 3.20. Search the Car
 - 3.21. Alarm Memory Recall
 - 3.22. Returning to Original Mode before Power Off
 - 3.23. Power Off and Wire Cut-off Alarm
 - 3.24. Parking Warning
 - 3.25. Alarm Mode of LED
 - 3.26. Alarm Pause
 - 3.27. Two-stage of Shock Sensor
 - 3.28. Alarm Trigger Identification
 - 3.29. Electric/Air Compressor Lock (Optional)
 - 3.30. Enable/Disable Shock Sensor
 - 3.31. Power Window
 - 3.32. Auto arming (optional)
 - 3.33. Engine Start (optional)
 - 3.34 GPS function
4. Dialer
 - 4.1. pictures of the Dialer
 - 4.2. Buttons of the Dialer

5. Phone Operation
 - 5.1. Note
 - 5.2. Telephone Operation Menu
 - 5.3. Seven Options in Main Menu
 - 5.3.1. Check System Status
 - 5.3.2. Listen In
 - 5.3.4. Car Control
 - 5.3.5. Change Password
 - 5.3.6. Set up Phone Number
6. GSM Location
7. Car Phone
8. SMS Control Order
9. Installation
10. Wiring Diagram
 - 10.1. Wiring Diagram of Mainframe
 - 10.2. Wiring Diagram of Central Locking System
11. Quality Warranty
12. Notes for Use
13. Trouble Shooting
14. Special Notice

1. Production Introduction

1.1 Basic Components

1mainframe, 1 GSM antenna, 2 remote controls, 1 GPS antenna, 1 dialer, 1 shock sensor, 1 siren, 1 speaker, 1 relay, 1 emergency help switch, 1 LED, 1 microphone, 1 bundle of output wire (12 holes), 1 bundle of input wire (10 holes), 1 bundle of input wire (6 holes), 1 bundle of start connection wire (4 holes), 1 operating instruction, 1 bundle of fastening wire

1.2 Buttons of the Remote Control

 arm
  disarm
  silent
  () search/start

1.3 Model and Apply

GPS car alarm system is compatible with all gas and diesel cars of 12V battery, with a central locking system, negative point meet metal.

1.4 Technical Specification

1.4.1 Mainframe

Working Voltage: 12V

Static Current (with GSM Module): 40mA -60 mA

Arm/Disarm Working Frequency: 300MHz-500MHz

Cover Area and Capacity: identical to the GSM system

Location Accuracy: 5-10M (which depends on the GPS satellite)

Alarming Duration: Alarm lasts until it is disarmed or the phone call is answered.

1.4.2 Voltage of the Output Control Point

Ignition Control: 0V

Siren Control: 12V

Petrol Control: 0V

Speaker Control: 12V

1.4.3. Input Checking Voltage

Door: 0V

Key: 12V

Foot Brake: 12V

1.4.4 GSM Module

Frequency: GSM 900MHz/1800MHz

Voltage of Serial Interface: 2.8V

Stand-by Current: 11-25mA

Static Current: 4mA

1.4.5 Remote Control

Working Voltage: 12V (1 A27 12V dry battery)

Working Frequency: 300MHz-500MHz

Control Distance: 20-100M

Static Current: 0mA

1.4.6 Working Conditions

Mainframe

Storage Temp.: -30°C-85°C

Working Temp.: -20°C-65°C

Working Humidity: 25% — 95%

Accessory

Storage Temp.: -40°C-100°C

Working Temp.: -20°C-85°C

Working Humidity: 25% — 95%

1.4.7 Size of the Mainframe

160 MM *138MM *38 MM

2. Original Settings

This first thing after installation is to set alarm phone numbers, emergency number and password. The user must set at least one alarm phone number to ensure the normal function of this system.

2.1 Insert a SIM Card and Install GSM and GPS Antenna

Before using this system, please buy a SIM card of GSM. Insert the card into the back of mainframe. Please remember the card number. Quick flashing of the signal LED indicates there is no GSM signal, while slow flash tells that the GSM signal is in good.

Install the GSM antenna above the SIM card socket, and GPS antenna install beside it.

2.2 Set and Modify the Password

Please change the original password of this system in order to prevent any wrong telephone call and illegal operation.

Solution 1

Press button *+# on the dialer to enter into the operation menu.

Solution 2

Use any phone to dial the SIM card number to enter into the **Main Menu of Operation**, then to " **Modify Password**" to set new password.

2.3 Alarm Phone Number

When there is an alarm trigger, this system will call the alarm phone numbers. Normally, one alarm phone number is enough for the normal alarm function. If needed, 2 or more phone numbers can be set into this system. In case of any alarm, this system will call these numbers by turns, which will never stop until one of these calls is answered. The 1st one is prior. At the same time, system sends short message to these numbers. If the 1st phone is answered, there will be no short message to the 2nd phone number.

2.4. Set Emergency Help Number

When the car is hijacked, the owner can get help from 2 ways. He can use the remote control to activate anti-hijacking mode. Please find the instruction in 3.14. Secondly, he can press the emergency help switch to activate anti-hijacking mode.

When the car enters into anti-hijacking status, the mainframe of this system will dial the emergency help number to get help. Once the call is answered, the LED will flash 3 times in 5 seconds. As the driver may be restrained to take any action in this situation, owner had better set his intimate's or family telephone into this emergency help number.

2.5. Delete an Alarm Telephone Number

Press # instead of numbers+ # when you are setting the alarm telephone number. The system will speak "Phone number deleted." Then press confirmation button to finish.

2.6 Password

To prohibit illegal operation on the car, the owner can set a password, 1 to 6-digital password, for this system. Originally, there is no password out of factory. It is suggested to set password after the purchasing.

Please note that after setting a password, the user should enter * + password + # to operate this system by using the dialer.

2.6.1 Setting and Modifying Password

Please change the original password of this system in order to prevent any wrong telephone call and illegal operation.

Operation Solution: Dial the number then enter into the **Main Menu of Operation**, after hear of " **Modify Password**" then set new password.

2.6.2 Delete a Password

Press # instead of any numbers + # when you are setting the password. The system will speak "password deleted." Then press confirmation button to finish.

2.6.3 Forget the Password

Solution: Make an alarm purposely by someone. Answering the alarm telephone, the owner can change the password by following the voice instruction.

2.7 Telephone Operation

2.7.1 Alarm Trigger Modes

When the user answers the alarm phone call he will hear the follow sentences.

- A. Warning, shock sensor activated
It means that the car is bumped or shocked heavily in armed mode.
- B. Warning, door opened
It means that the door is opened in armed mode.
- C. Warning, engine started
It means that the ignition is turned on and car is started.
- D. Warning, power off
It means that the power supply is cut off or the voltage is low.
- E. Warning, please help
It means that the owner is hijacked, and he needs help.

2.7.2 Real-time Alarm Report

If there is alarm on the car when the user is using a phone to operate this system, the system will stop the operating to report the alarm modes and then auto return the main menu.

2.7.3 The owner can arm his car by telephone when he leaves the car for long vocation, which can also treat emergency of dialer or remote control loss.

Armed by telephone, the car must be disarmed by telephone or dialer.

2.7.4 Car Immobilizer

If car is stolen or hijacked, the owner can dial the mainframe to enter car control menu and activate immobilizer. The turn lights flash for 10 seconds, and then the siren beeps with light flash for 10 seconds. After that, the engine is stopped in 10 seconds.

If the car is stopped by phone, only a release by phone can start the engine. Both stopping and starting order are mandatory orders. They only switch the pneumatic /electrical circuit on/off, which doesn't affect the armed/disarmed condition.

Warning! It is dangerous when this order is carried on the highway. It is suggested to choose Voice Broadcast first and let the thieves have several seconds to stop the car. The owner can check whether the car is stopped or not by Check System Status first, and then activate the immobilizer.

2.7.5. Listen In

The user can listen in car. In the mode of **Listening In**, press * to go on and press 0 to return.

2.7.6 Voice Broadcast

When someone steals the car, the driver can frighten the thief by broadcasting to the car before he

reaches his car. Press 0 to exit.

3. Function and Operation

3.1 Sound and Light Alarm

Shortly press . Car door will be locked, and the system enters into sound and light alarm mode.

3.2. Mute Alarm

In disarmed mode, shortly press . Car door will be locked, and the system auto enters into mute alarm mode after 3 seconds.

3.3 Armed Reminder (optional)

Armed by remote control, this system will dial the 1st alarm phone number and then hang up after the phone rings for 5 seconds. There is no need for the user to answer this phone call. At the same time, a short message" Armed" will be sent to the 1st phone number.

3.4. Trigger Alarm (optional)

	Trigger mode	Alarm mode	Voice Notice	SMS
Sound light alarm	In 15 seconds, there is only one shock.	Siren interval beep 5 times, turn light flashing	No calling to car owner	
	In 15 seconds, there is shock over two times.	Siren interval beep 30 seconds, turn light flashing	Calling to car owner: Warning, shock sensor activated	Shocking N(S)XX° YY' ZZ' ' E(W)XX° YY' ZZ' VX. XX DXXX. XX
	Open car door	Siren long beep 25 ± 5 times, turn light flashing	Calling to car owner: Warning, door opened	Door open N(S)XX° YY' ZZ' ' E(W)XX° YY' ZZ' VXX. X DXXX. XX
	Open the engine		Calling to car owner: Warning, door opened	Door open N(S)XX° YY' ZZ' ' E(W)XX° YY' ZZ' VXX. X DXXX. XX
	Engine start		Calling to car owner: Warning, engine started	Engine started N(S)XX° YY' ZZ' ' E(W)XX° YY' ZZ' VXX. X DXXX. XX

	Step on foot brake		Calling to car owner: Warning, engine started	Footbrake trigger N(S)XX° YY' ZZ' , E(W)XX° YY' ZZ' VXX. X DXXX. XX
	Power off		Calling to car owner: Warning, power off	Power off N(S)XX° YY' ZZ' , E(W)XX° YY' ZZ' VXX. X DXXX. XX
	Emergency help		Calling to car owner: Hijacked, please help	Help N(S)XX° YY' ZZ' , E(W)XX° YY' ZZ' VXX. X DXXX. XX
	Arm the car	Siren interval beep 3 times, turn light flashing		Please arm N(S)XX° YY' ZZ' , E(W)XX° YY' ZZ' VXX. X DXXX. XX

1. These alarm above will continue if the trigger alarm continues.

2. In case of any alarm, this system will call the 1st phone number. Not answered, it will call the 2nd phone number. The call will continue by turns, which will never stop until one of these calls is answered. At the same time, system sends short message to these numbers. If the 1st phone is answered, there will be no short message to the 2nd phone number.

3.5 Third Alarm Phone Number (optional)

This system can hold 3 alarm phone numbers if it is needed.

3.6 Alarm Report

If there is another alarm trigger when the previous alarm phone is answered, this system will report the latest alarm immediately. However, the shock trigger alarm will not be reported when there is another alarm.

3.7 Alarm priority

When connected the GSM mainframe, alarming happened before enter the password .the connection would be but automatically .then dial the number to alarm phone that used set.

3.8 Reminding to Set the Phone Number Beforehand

This system will remind the owner to set phone number before setting a password to treat the emergency when car owner forget the password. The voice instruction is "Please set up phone number."

3.9 Safety Reminding (optional)

After the ignition is turned on, the system will speak "Pleas wear your seat belt."

3.10 Dialer/Remote Control Learning Code

Close the door, and step on foot brake. Turn the key from OFF to ON for 3 times and stop in the position of ON. When turn light flash 5 seconds, press any button of dialer. Turn light will flash 3 times, and siren beeps 3 times. Dialer learned code successfully.

3.11 Reporting Incoming Telephone Number

When someone calls the owner in disarmed mode, the system will ring and speak the incoming telephone number.

3.12 Hacker Memory

When someone tries to enter this system by putting the wrong password for three times, the line will be cut off automatically. When car door is opened, this system will speak "A hacker wants to enter your system. The number is ***. Press # to continue." In 10 seconds, press # to listen the number again. Press other button to exit.

3.13 Disarming and Auto Rearming

Shortly press  to disarm and unlock the door. If the car is armed by dialer or phone, remote control will fail to disarm it. Only a phone or dialer can disarm this system. After disarming, if door is not opened in 25 seconds, this system will return to original armed mode automatically.

3.14 Emergency Help Alarm

In case of any hijack during the course of driving, the driver can get help his friends, family or policeman through the following method.



- A. Press  for 2 seconds. Lights flash and siren beeps.
- B. Press emergency help switch for 2 seconds. LED flashes 2 times in every 5 seconds.

This alarm system will dial the emergency help number automatically, and send SMS to the emergency help number. At the same time, his friends or family can put through the line to monitor the situation in the car. Press # to release the alarm. At this time, the LED will flash 3 times in every 5 seconds.

3.15 Remote Trunk Release

Press  twice in disarmed mode. This system will speak "Trunk opened."

3.16 Help

Press  () for two seconds in running, siren will beep for 30 seconds with turn light flashing at same time. Press any button to stop.

3.17 Arming Reminder (optional)



When the ACC is off, if the car is not armed in 10 seconds after the door is closed, the system will beep 3 times and lights will flash 3 times to remind the car owner to arm the car.

2 minutes after the door is closed, if the car is still not armed, this system will auto call 1st phone number with short message, and speak "Please arm." If the user has chosen the auto arming function, there will be no phone call and SMS.



3.18 Closing Door Reminder

If the car is parked and armed with door not closed properly, the system will beep for 3 times and the turn lights flash. In this case, the owner should disarm the car and close the door properly. Otherwise, there will be beep 10 seconds later.

3.19 Automatic Central Locking System

When ACC is on, step on the brake after 15 seconds, the door will be locked automatically. When ACC is off, the door will be unlocked automatically. In driving course, press  to lock the door and press  to unlock the door.

3.20 Searching the Car

In armed mode, shortly press , the turn lights flash for 15 seconds. In armed mode, a short press of  will make the turn lights flash and siren beeps for 15 seconds, which indicates the location. Press any button on the remote control to stop the beep and flash.

3.21 Alarm Memory Recall

If the car has been triggered, the siren will beep once and the lights flash for 3 seconds when the door is opened.

3.22 Returning to the Original Mode before Power Off

If the system is destroyed, it can go back to the original condition 5 seconds after the power is recovered.

3.23 Power Off and Wire Cut-off Alarm

In armed mode, if the power is off or the wire of mainframe is cut off, this system will dial the 1st phone number in 3 seconds. It speaks "Warning! Power off."

3.24 Parking Warning

When ACC is off, the lights will flash 15 seconds to give warning to the car behind when the door is opened.

3.25 Alarm Mode of LED





In armed mode: LED flash 2 times, stop for 1 second...

Triggered by shock: LED flash 3 times, stop for 1 second...

Trigger from power-on: LED flash for 2 seconds, stop for 2 seconds...

Disarming after being triggered: LED flash for 3 seconds

3.26 Alarm Pause

In alarming, press  () or  or  to pause the alarm. This system is still in armed mode. But can not lock and unlock.

3.27 Two-stage of Shock Sensor

In armed mode, if the car is vibrated slightly, the light will flash for 5 times with beep for 5 times. If it is suffered from continuous vibration, the flash and intermittent beep will last 25±5 (mute no beep).

3.28 Alarm Trigger Identification

There are 2 kinds of alarming. Shock and vibration induce intermittent beep (mute no beep); while door open and engine start induce continuous beep (mute beep).

3.29 Electric/Air Compressor Lock Optional

Switch the LUCKY TYPE off in the mainframe, air compressor lock will work; switch the LUCKY TYPE on, the electric lock will work. Selecting the lock should be carried under power off condition.

3.30 Enable/Disable Shock Sensor

In order to prevent wrong shock alarming, the user can disable shock sensor according to voice instruction.

3.31 Power Window

If the car is installed with a power window, this system will auto close the windows 3 seconds after being armed. It needs 25 seconds to close all the windows. In this period, the shock sensor fails. Without a power window, the shock sensor works 3 seconds after this system is armed.

3.32 Auto Arming (optional)

Parking the car, driver closed the door. If the car is not armed in 1 minute, this system will enter into silent armed mode with door unlocked.

3.33 Engine Start (optional)

In armed mode, short press start button. The lights will flash for 4 seconds. Press start button again, this system will try to start the engine. If it succeeds, siren will beep once. Otherwise, the siren will beep 3 times.

After being remote started, the engine will be on for 8 minutes. Press  to stop the engine.

Attention! Before the engine is remote started, the user should make sure that the gear is in neutral place and the hand brake is should be pulled on. To remote start the air conditioner, it is should be on before the ignition is turned off. The engine will be off after 8 minutes. If it is remote started by remote control, any brake and key spinning in ACC will cut off the ignition.

If a password has already been set into this system, the user should put the password before the first letter. For example, send "***** Arm#" to arm the car. If there is no password, the message should be "_Arm#". If do not set the password yet, it must keep a blank before the first capitalized letter. If set the password, it must keep a blank before the password.

If no phone number is in this system, the returned message will be "(1), 2), 3)".

3.34 GPS function

3.34.1 GPS message in state of alarming

When the system alarmed, the registered alarm phone will receive the SMS with status of alarm, latitude, longitude, velocity and direction, e.g.

Door open,

N(S)XX° YY' ZZ' '

E(W)XX° YY' ZZ'

VX.XX

DXXX.XX

They mean latitude (N/S), longitude (E/W), velocity (V), direction (D) respectively.

3.34.2 Check the location of car in real time

The user can send specific short message to check the car's status any time and any where e.g.: *P#, if the password already been set, the format of check is: password*P#, the system will send a message back to user with GPS message, e.g.:

N(S)XX° YY'ZZ"

E(W)XX° YY'ZZ'

VX.XX

DXXX.XX

If send password wrong, the GPS system will send back a message: Wrong password.

3.34.3 How to check the location of car with system message

The user can track the place with the message in PC PDA and Google earth map.

NOTE: If the checking format is different as system message .it has to change our GPS system message to the checking format e.g.

Our GPS message format: N(S)XX° YY'ZZ" E(W)XX° YY'ZZ'

Different format: XX YY.YYYY'E (W), XX YY.YYYY'N(S)

Conversion process: let the last ZZ"N(S) and ZZ"E (W) divided by 60 to checking format YYYY ('E) and YYYY ('N).

The Google map loaded as below:

<http://earth.google.com/tour/thanks-win4.html>

Click:



1. Download the installation procedure.
2. After installation, it would show the following at desk:



Click it to enter "Google-map", click  , and enter the interface:



3. Enter the longitude and latitude you gained from message,

Click inquiry key  , and you can see the position of vehicle.

3) Open the tracking function

If the user wants to track the system time, the user can set the time back message function

1. send back message every 4 minutes(password*T1#)
2. send back message every 8 minutes(password*T2#)
3. send back message every 12 minutes(password*T3#)
4. send back message every 16 minutes(password*T4#)
5. send back message every 20 minutes(password*T5#)
6. send back message every 24 minutes(password*T6#)
7. send back message every 28 minutes(password*T7#)
8. send back message every 32 minutes(password*T8#)
9. send back message every 36 minutes(password*T9#)

To cancel the function, please send message (password*T0#)

If have not set password, directly send *Tx#(x=0~9), spacing interval is multiple of 4.

If send password wrong, the GPS system will send back a message: Wrong password.

If send format wrong, the GPS system will send back a message: Failed, correct format is password*Tx#(x=0~9)

4. Dialer

4.1 Picture of the Dialer

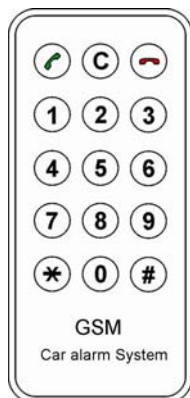

Picture 01

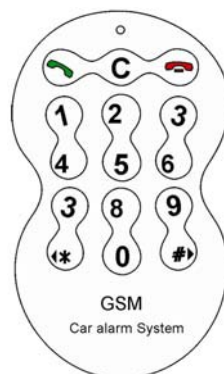

Picture 02

4.2 Buttons of the Dialer

- | | |
|--------|--|
| 0-9.*# | Phone button |
| YES | Answer phone call, call out |
| C | Delete the last number |
| NO | Hang up, exit the system directly (optional) |

4.2.1 Pressing 0-9, the user can hear the number he dialed, with toot by other buttons.

4.2.2 How to Use the Dialer

Phone numbers can be set by dialer. Press No, and then *password# to enter into the system. If there is no password, press *# to enter.

4.2.3 Dial a Phone number

Press button NO on the dial-pad firstly, and then enter the phone number. You can delete the last number you enter by pressing C. Finishing all the numbers, press YES. The system will repeat what you have entered, "The phone number you entered is ***." 3 seconds later, the number will be connected. In the course of dialing and talking, press NO to hang up.

4.2.4 Answer a Phone

When there is an incoming call, the system rings. Press NO to hang up and YES to answer.

5. Phone Operation

When the user answers a call from the mainframe, he can press the corresponding numbers to control the system.

5.1 Note

5.1.1 When the user connected the car from his side, he should choose Car Control and enter password to enter into the system. If there is no password, he can enter into the system directly.

5.1.2 When the user answered an alarm phone call, there is no need to enter password to enter into the system.

5.1.3 If the user enters a invalid button, the system will repeat the options again.

5.1.4 In submenu, press 0 to return the upper menu. In the main operation menu, press 0 to exit.

5.1.5 When the line is get through and no order is from user's side, there will be short beep after 40 seconds, with another beeps in every 10 seconds after. At last, the system will be cut off automatically after 1 minute. Press # to delay the talking time.

5.2 Telephone Operation Menu

5.2.1 Telephone Operation (in disarmed mode)

Dial the number of mainframe, and enter the password according to voice instruction.

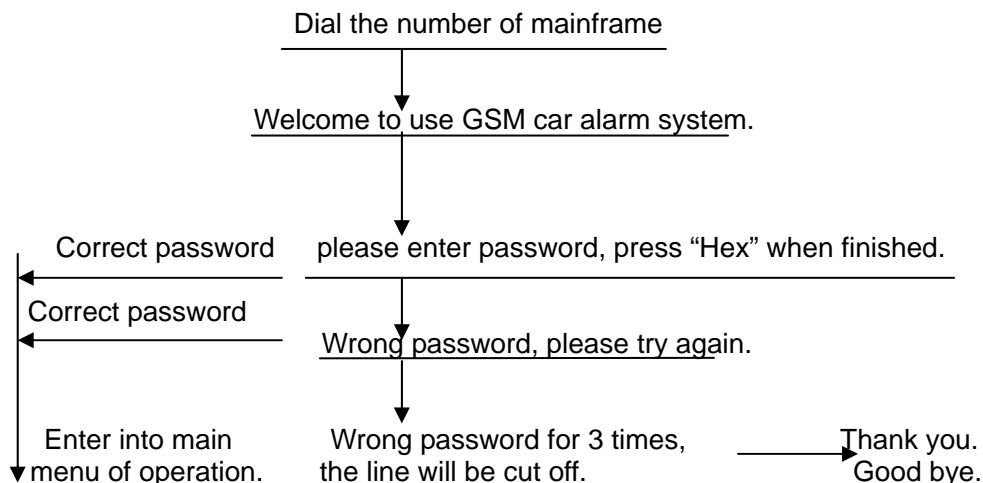

5.2.2 Car Phone Operation (in driving course)

Dial the number of mainframe, and enter the password according to voice instruction.

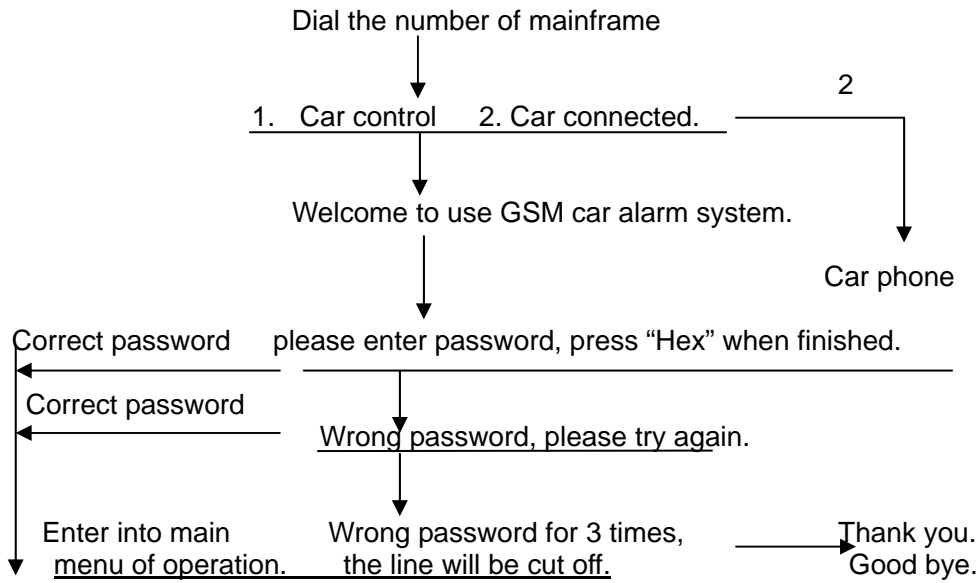

When there is an alarm and the call is answered, there will be no need to enter password. After the sentence is finished, the system will enter into main menu of operation.

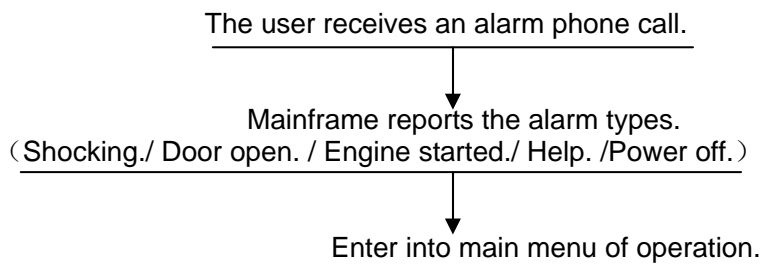

5.2.3 Main Menu of Operation

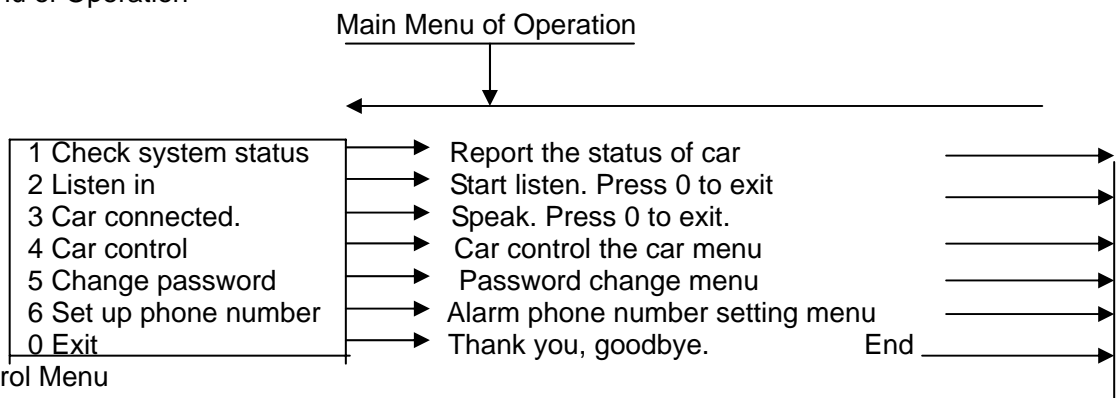

5.2.4 Car Control Menu

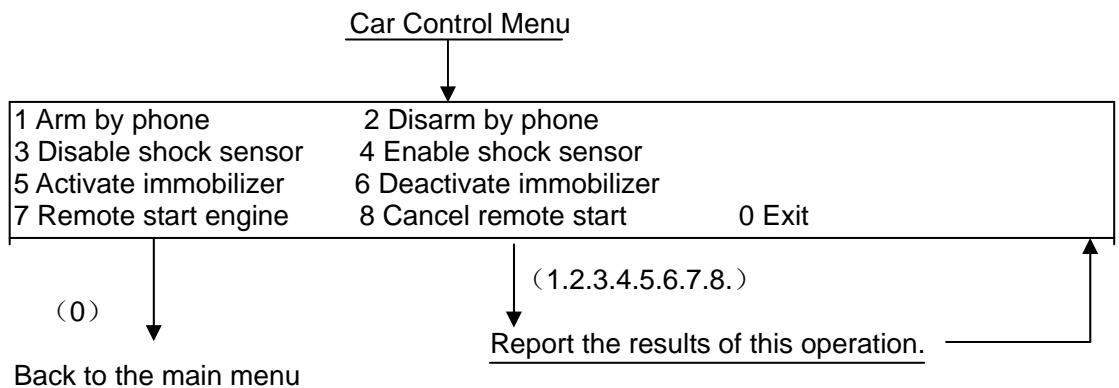

5.2.5 Password Change Menu

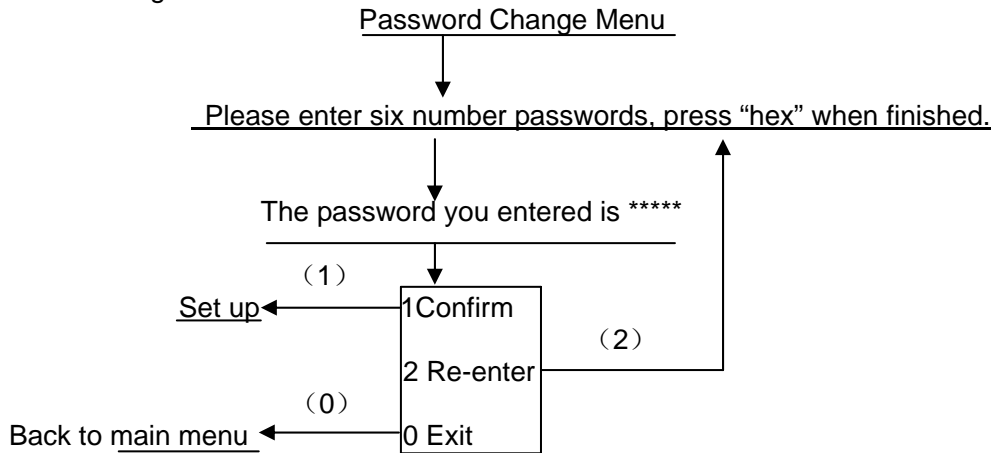

5.2.6 Alarm Phone Number Setting Menu

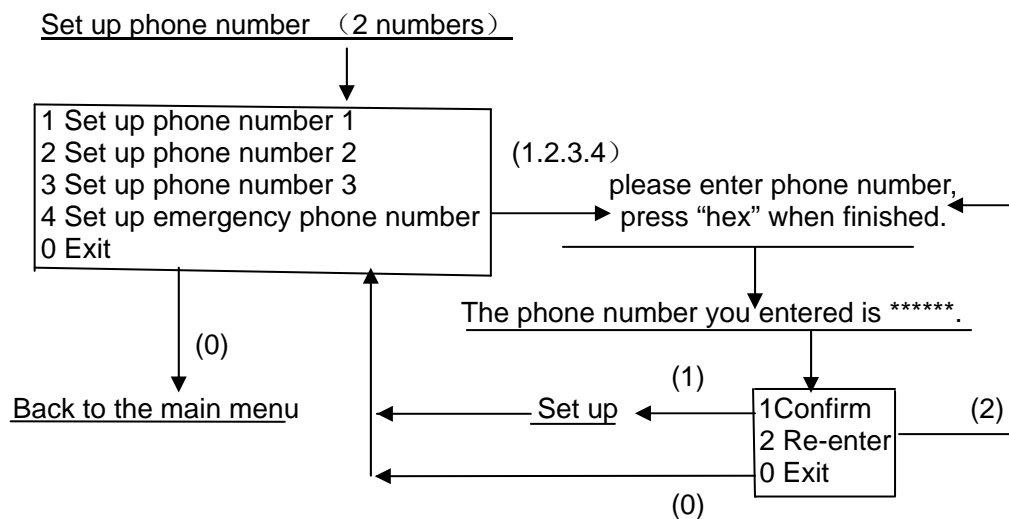
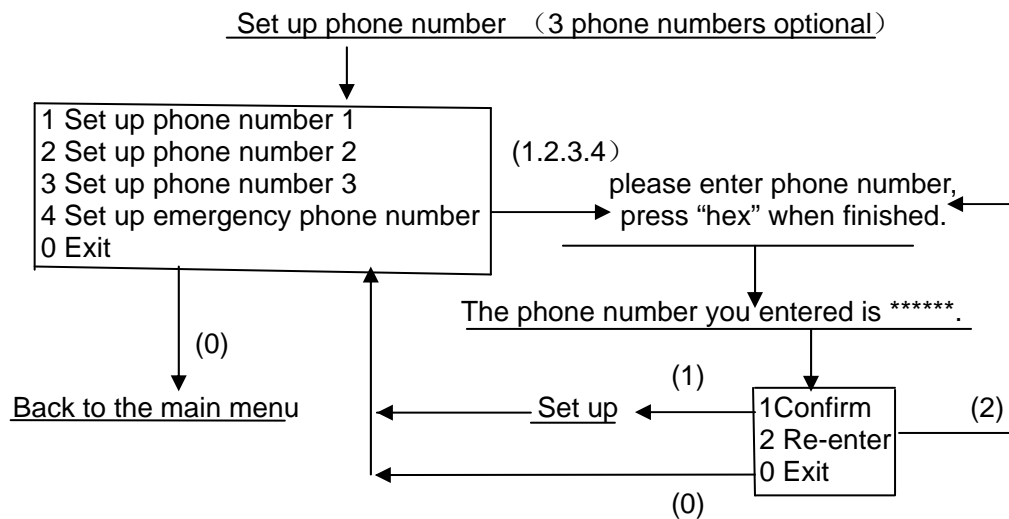

5.3 Seven Options in Main Menu

5.3.1 Check System Status

Dial the number of mainframe and choose 1 in the main menu to check status of the car. The results are as follows.

Disarmed—Car is disarmed by remote control or phone.

Armed——Car is armed by remote control or it is auto armed.

Armed by phone——Car is armed by phone.

Warning! Door is opened.—— Door is unlocked.

Engine is running.—— Car is running or ignition is turned on.

Immobilizer is activated.—— Car is immobilized.

Immobilizer is de-activated. —— Car is allowed running.

No phone number.—— There is no alarm phone number and emergency number in the system. This system needs at least 1 alarm phone number for working normally.

5.3.2 Listen In

Dial the number of mainframe and choose 2 in the main menu to listen the voice inside the car. When the owner gets through the line, and then listens the voice, thieves inside the car will not be aware of it.

In the mode of listen in, the owner can press * to shift from talking to non-talking. Press # to delay, and press 0 to exit.

5.3.3 Car Connected

Dial the number of mainframe and choose 3 in the main menu to broadcast to thieves inside the cars.

In connected mode, press # to delay, and press 0 to exit.

5.3.4 Car Control

Dial the number of mainframe and choose 4 in the main menu to control the car. Submenu is as follows.

Press 1 to arm the car by phone and lock doors. The system enters into light and sound armed mode in 3 seconds. There will be voice notice at the same time, "Armed by phone".

Press 2 to disarm by phone and unlock doors. There will be voice notice at the same time, "Disarmed by phone". (Notice: When the car is armed by phone or dialer, it is can only be disarmed by phone or dialer.)

Press 3 to disable shock sensor. If there is a shock trigger, there will be no alarm.

Press 4 to enable shock sensor. Shock sensor works.

Press 5 to activate immobilizer. The car will be stopped after 10 seconds. After immobilizer is activated, only an order of Deactivate Immobilizer can make the car start normally.

Press 6 to deactivate immobilizer.

(Note: Activate Immobilizer and Deactivate Immobilizer are absolute orders, which only control the pneumatic circuit/electric circuit, no change of arm/disarm mode.

Press 7 to remote start the engine.

Press 8 to cancel remote engine start. The ignition will be off and the engine will be stopped.

5.3.5 Change Password

Dial the number of mainframe and choose 5 in the main menu to change password.

There is no factory password in this system. Before setting a password, the user must set a phone number at least. Otherwise this system will give voice notice, "No phone number".

If the owner forgets the password, he can trigger alarm purposively; for example, open the door by key in armed mode. The system will dial the alarm phone number. At this time, no password is required before he enter into the control menu. Following the voice instruction, the owner can change the password by pressing 5.

It is suggested to set a password before using this system. Otherwise, somebody who knows the alarm phone number can also operate the car.

5.3.6 Set up Phone Number

Dial the number of mainframe and choose 6 in the main menu to set up alarm phone number. 2 or 3 alarm phone numbers and 1 emergency number can be set into this system.

6. GSM Location

6.1 The system support GSM mobile network location. As long as the local telecom companies supply the mobile locating service, this system can locate the car.

6.2 Having installed this system, the owner should go to the local telecom to apply the mobile locating service.

7. Car Phone

7.1 The usage of the GSM mobile phone in the mainframe is the same as the normal mobile phone.

7.2. The car mobile phone is wireless, hand-free, with microphone and loud speaker. The car mobile phone can only be used in disarmed condition. Dial the number, the system will remind you by voice: 1 Car Control 2 Car Connected. Select 2 to enter into mobile mode.

8. SMS Control Order

The user can send specific short message to the system to control the car, and also a short message will be back to tell the user whether the operation is done successfully.

Short message are as follows will be displayed on the alarm phone numbers.

	Function	Message back	
		Successful	Failed
Arm	Remote arm the car.	Arm Successfully	Failed
Disarm	Remote disarm the car.	Disarm Successfully	Failed
Start	Remote engine start.	Start Successfully	Start Failed
Stop	Remote stop the engine.	Stop Successfully	Failed
Phonelist	List all the phone numbers that have been set in this system.		
Phoneclear	Clear all the phone numbers that have been set in this system.		
Phone1clear	Clear phone number 1.		
Phone1clear; 2clear	Clear phone number 1 and 2.		

9. Installation

9.1. Please select experienced technicians to install this system.

9.2 The installation should be carried in the working condition for this system.

9.3 Prevent this system from dust and humidity.

9.4 Install this system in a secret place.

9.5 Connect the wires of the mainframe. The relay can control petrolic circuit or electric circuit. It suggested connecting it to petrolic circuit.

9.6 Connect the wires of other wires. Leave the plug unplugged.

9.7 Fixing, wiring connecting, binding should be carried on carefully.

9.8 Turn the backup battery on. Turn the switch to ON position.

9.9 Connect the plug of mainframe.

9.10 Connect the microphone to the mainframe.

9.11 Please use nylon strap, flexible conduit or insulating tape to fix all the joints and wires. The microphone should be place away form speaker and GSM antenna, and the wire of microphone should not be bound with other wires.

9.12 Fixing, wiring connecting, binding should be carried carefully.

9.13 Read the operating instruction, wiring diagram and illustrated diagram carefully. This company is not

liable for any failure results from wire changes without permission.

9.14 Please test this system according to this manual after installation.

10 Wiring Diagram

10.1. Wiring Diagram of Mainframe

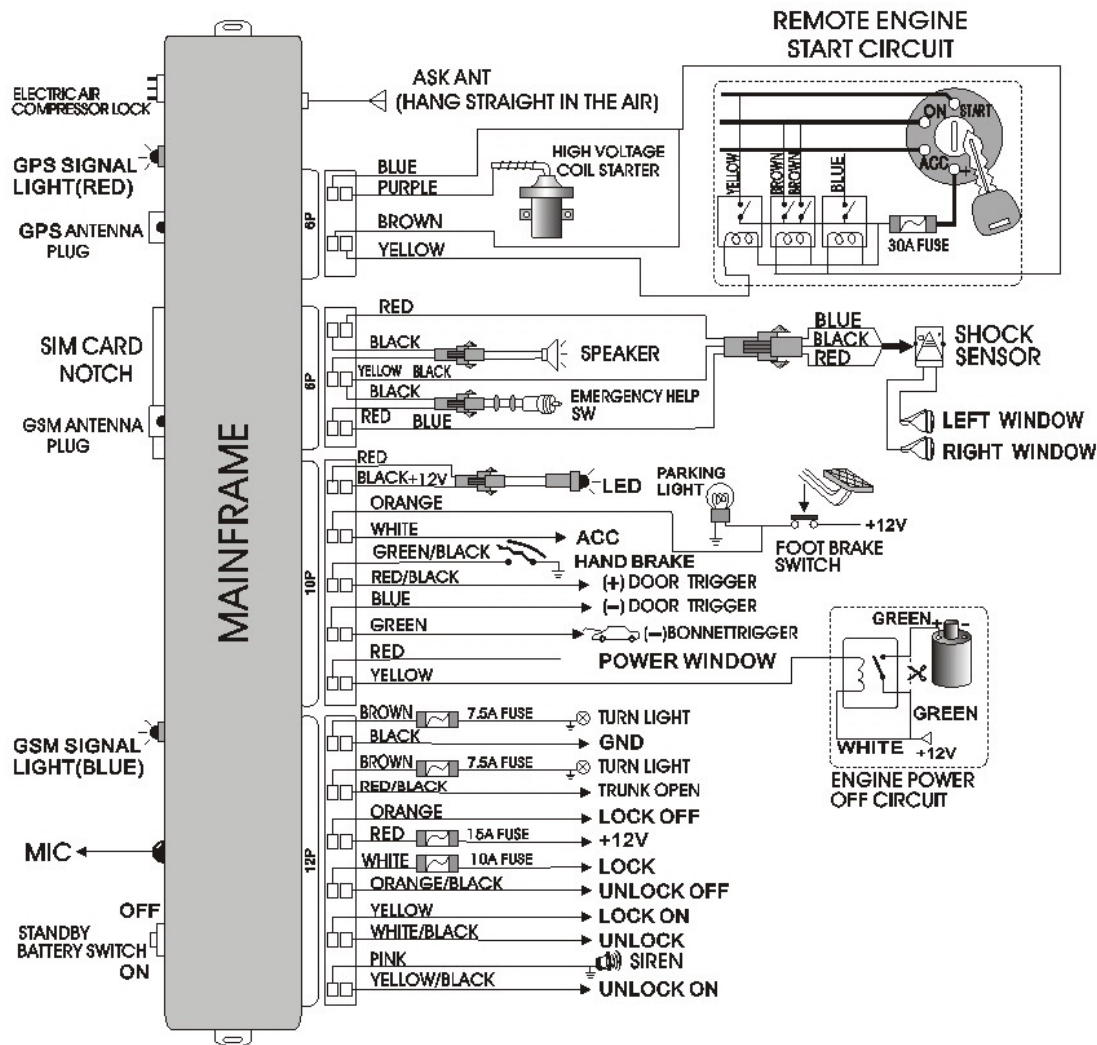

10.2. Wiring Diagram of Central Locking System

STRUCTURE OF CENTRAL LOCK

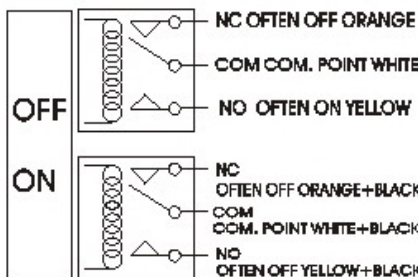

NEGATIVE TRIGGER

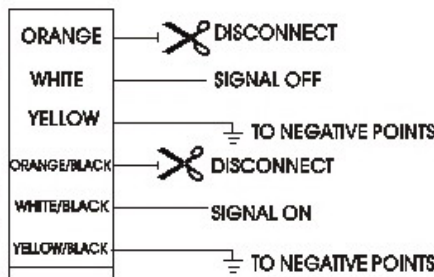

POSITIVE-NEGATIVE TRIGGER

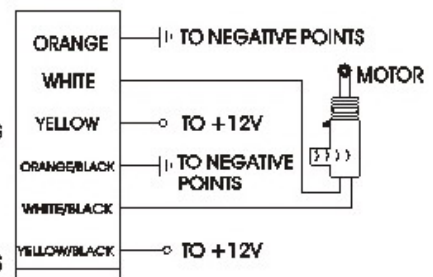

POSITIVE TRIGGER

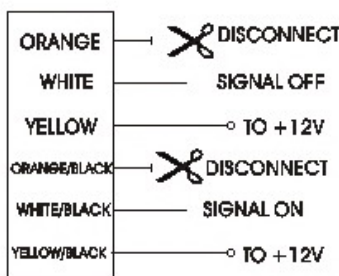

CIRCUIT FOR PETROLIC LOCK

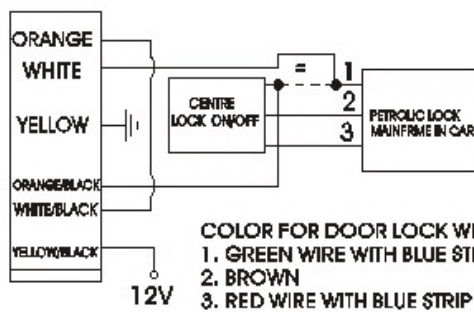

POSITIVE CIRCUIT TRIGGER

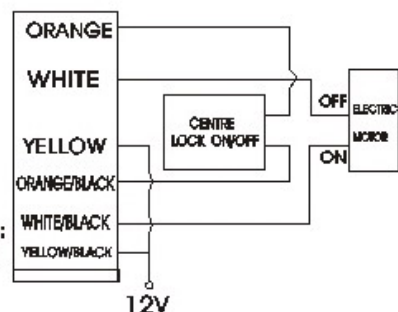

11. Quality Warranty

11.1 This system is warranted to be free of defects in material and workmanship for 1 year from the date of purchase. With the Warranty Card, purchaser can replace or repair the defect in the product at the maintenance agency.

11.2 This warranty doesn't extend to any defect, malfunction or failure caused by abuse or misuse by the Operating Instruction. In no event shall the manufacturer be liable for any alarm system altered by purchasers.

12. Notes for Use

12.1 It is suggested to use a SIM card which can be charged by other phones.

12.2 Please check the balance in the SIM frequently to make sure there it can work properly.

12.3 Try to keep the vehicle in the covering area of GSM signals.

12.4 Keep the password secret. When the password is known by others, please change it in time.

12.5 In disarmed mode, when the key is used to open the door and start the engine, there is alarm. Armed by phone, the remote controls fail. Only disarmed by phone the car can be started. It is suggested to arm the car by remote control.

12.6 Before using the Remote Engine Start order, make sure the gear is in neutral position.

12.7 On the highway, it is dangerous to use Activate Immobilizer order. It is suggested to broadcast to the thief and give him several minutes before giving this order. The owner can check the car status by Check System Status first. Confirming the car is stopped, the owner can give this order.

13. Trouble Shooting

Many apparent malfunctions are caused by maladjustment and incorrect connection. If you encounter any troubles listed in the following table, please check and adjust according to the methods. Should the troubles still persist, contact the dealer.

Troubles	Methods of Checking and Adjustment
Remote controls fail.	Check the whether the car is armed by phone.
The dialer cannot dial any phone numbers.	Check whether the SIM card was plugged in when the power of mainframe is on.
The car cannot be started normally.	Check whether the immobilizer is activated.
When there is alarm, no phone call to the alarm phone numbers.	1. Check whether the alarm phone numbers are incorrect. 2. Check whether there is balance in SIM card.
When there is no alarm, the system call alarm phone numbers.	Check the sensitivity of the shock sensor, and adjust it to a moderate level.
When you use the dialer to dial a number, there is no voice in the speaker.	Check whether the connection plug is in correct place.
The central lock doesn't work or is abnormal.	1. Check the actuator. 2. Check the wire, fuse. 3. Read the installation instruction and wiring connection for central lock.
The car cannot be started. /System give notice that it is started successfully, but the system is still trying to start the ignition.	1、 The hand brake test line is not connected properly. 2、 The lamp test line of engine is not connected properly.
The siren beeps all the time and cannot be released by remote control after this system is installed.	1. Check whether the wire is connected correctly. 2. Check whether the fuse of the mainframe is burned out. 3. Check whether the model of mainframe and that of remote

	control is the same.
Parked and armed, this system alarms when a truck or a cart passes by.	Check and adjust the sensitivity of the shock sensor.

14. Special Notice

- As the signal from remote control of the car is transmitted via RF, the control distance of remote control may be affected by buildings, geography conditions, and weather sometimes.
- Read the Operating Instruction and wiring connection carefully before the installation. Please make out electro circuit of car first.
- The mainframe should be installed away from high temperature, humidity and other electronic items. Plug the wire plug into the mainframe, and wrap the wire top with a paste-tape. Please take out the control wires, such as power supply wire, ignition wire, and light wire, door open signal wire. If there is no door open signal wire, it is needed to install corresponding sensor switch.
- The power supply wire should be installed after all other wires being installed. Please wrap all the connection point with pastern.
- It is suggested that the antenna should be installed close to the windshield. Any antenna folding, cutting and grounding is prohibited.
- The shock sensor should be pasted close to the car. Adjust the sensitivity to a good level.
- If the remote control distance shortens and the LED on remote control is dim, please change the battery.
- When battery of the remote control is low, please change it in time. Please choose high capacity alkaline battery. Pay attention to the anode and cathode of the battery.
- The manufacturer preserves the authority to change the design and function without preannouncement.

Warranty Card

IMPORTANT! This card should be completed by selling dealer. To receive product support service, technical updates and upgrades, please keep this card after purchasing.

Customer's Name: _____

Address: _____

Dealer Name: _____

Dealer Address: _____

Date of Purchase: _____

Date Installed: _____

Product Model: _____

Product Code Number: _____

Maintenance Record:
